

**IRIZAR**

**IRIZAR HEAVY INDUSTRIES INC**  
1512 ADAMSON VIEW, EDMONTON  
ALBERTA T6W 0V4, CANADA  
PHONE: 1 780 450 6695  
WEB: WWW.IRIZAR.COM

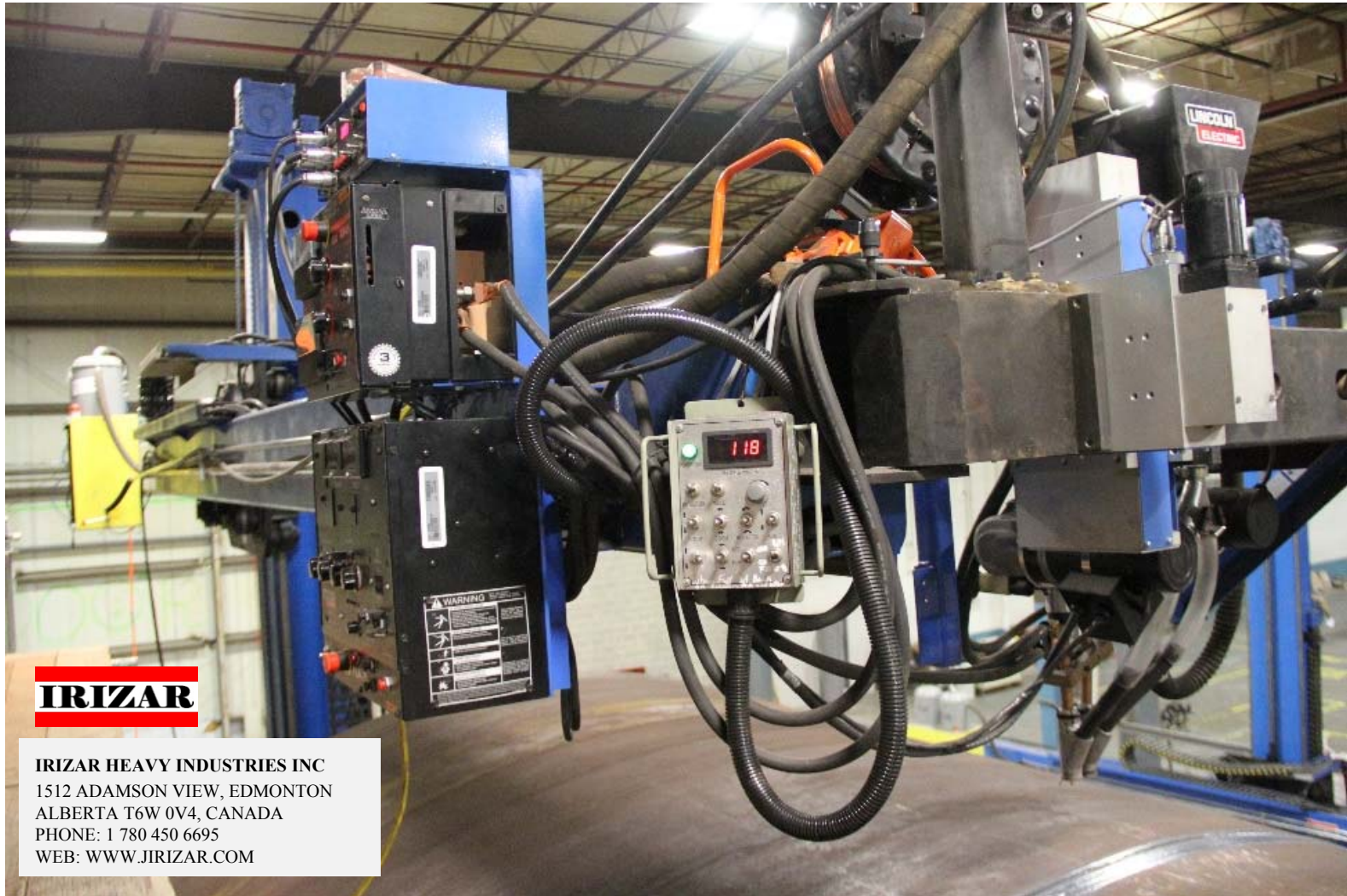



**IRIZAR**

IRIZAR HEAVY INDUSTRIES INC  
1512 ADAMSON VIEW, EDMONTON  
ALBERTA T6W 0V4, CANADA  
PHONE: 1 780 450 6695  
WEB: WWW.IRIZAR.COM



**IRIZAR**

**IRIZAR HEAVY INDUSTRIES INC**  
1512 ADAMSON VIEW, EDMONTON  
ALBERTA T6W 0V4, CANADA  
PHONE: 1 780 450 6695  
WEB: WWW.IRIZAR.COM

## WELDING MANIPULATOR SPECIFICATIONS & FEATURES

1. Types: Mobil with Motorized Trolley or Fixed (Self Stand)
2. Boom vertical effective expansion (m): A (next page)
3. Boom horizontal effective expansion (m): B (next page)
4. Boom expansion speed (in-out): From 0.12 up to 1.2 m/min
5. Boom lifting speed (up-down): Sheet (next page)
6. Max load at boom extremity: Sheet (next page)
7. Trolley motorized (approx.): 1.50 m/min. **With variable speed (starting manufactured 2015) from 0.30 to 3.0 m/minute**
8. Column rotation motorized (approx.): Motorized. **With variable speed (starting 2015) from 0.03 to 0.30 RPM**
9. Column rotation motorized:  $\pm 180^\circ$
10. [Manual cross slide](#) for single head: **Included**
11. Column height (approx.): C (next page)
10. Remote Control Box:
  - Cable length: 12 m
  - Variable speed on Boom in-out forward/stop/reverse
  - Potentiometer and digital display in mm/min or IPM
  - Boom lifting up/stop/down
11. Main Control Box:
  - Variable speed on column rotation: forward/stop/reverse
  - Variable speed on trolley: forward/stop/reverse
12. Safety:
  - **Boom anti-fall safety device**
  - **Trolley anti-fall safety device**
  - **Limited switches in all directions**
13. Quality:
  - **Gear boxes are made of ANSI-1045 or equivalent**
  - **Motors and control box with IP 54 protection against dust and heavy rain. Irizar WM is able to work in rain forest or desert.**
  - **Counter weight system. Ensure smooth boom vertical travel**
  - **Boom cable organized. Ensure cables well organized**
  - **Frequency Driver made by [TECO](#)**
  - **Stress Relieved Column and Boom. Ensure the release of tensions after welding process**
  - **Shot blasted. Ensure Irizar WM paint lasts longer**
  - **Power Source platforms with rotation along with the column. Reduce voltage drop since power source move with the trolley. Max load capacity of 1.5 MT**
14. Power: Sheet (next page)
15. Input Power: Standard power is 240 V, 60 Hz, 3 P. Available others under customer request
16. [Operation Manual](#)
17. Electric Diagram
18. One Year [Warranty](#)
19. Optional:
  - Lincoln Electric SAW Equipment (DC 1000 & NA-3S)
  - [Flux Recovery System Model FRU-80](#)
  - [Motorized cross slide](#)
  - [Seam Tracker Model 100](#)
  - CE Mark



**IRIZAR HEAVY INDUSTRIES INC**  
1512 ADAMSON VIEW, EDMONTON  
ALBERTA T6W 0V4, CANADA  
PHONE: 1 780 450 6695  
WEB: WWW.JIRIZAR.COM

Model	Boom							Column		Trolley/Base		Power (kW)	Weight (MT)
	(A) Vertical Expansion (m)		(B) Horizontal expansion (m)	Up-Down speed (m/min)	In-Out (m/min)	Traveling precision Speed (%)	Max load at boom extremity kgs @ 12°GC	Rotation Angle ± 180°	(C) Total height (m)	(F) Rail $\phi$ to $\phi$ (mm)	speed (m/min)		
	Net	Min-Max											
WM 1515	1.5	0.53~2.03	1.5	0.30	0.12~1.20	± 2%	100	manual	3.00	1052	1.50	0.91	1.50
WM 2020	2.0	0.53~2.53	2.0	0.30			100	manual	3.50	1052	1.50	0.91	1.75
WM 3030	3.0	0.75~3.75	3.0	1.00			200	motorized	5.50	1600	1.50	2.75	3.00
WM 4040	4.0	0.75~4.75	4.0	1.00			200	motorized	6.50	1600	1.50	2.75	4.00
WM 5050	5.0	1.10~6.10	5.0	0.90			300	motorized	7.80	1798	1.50	3.35	5.00
WM 6060	6.0	1.10~7.10	6.0	0.90			300	motorized	9.00	1798	1.50	3.35	6.50
WM 7060	7.0	1.20~8.20	6.0	0.90			300	motorized	10.00	2200	1.50	4.25	11.00
WM 8060	8.0	1.20~9.20	6.0	0.90			300	motorized	11.00	2200	1.50	4.25	13.00

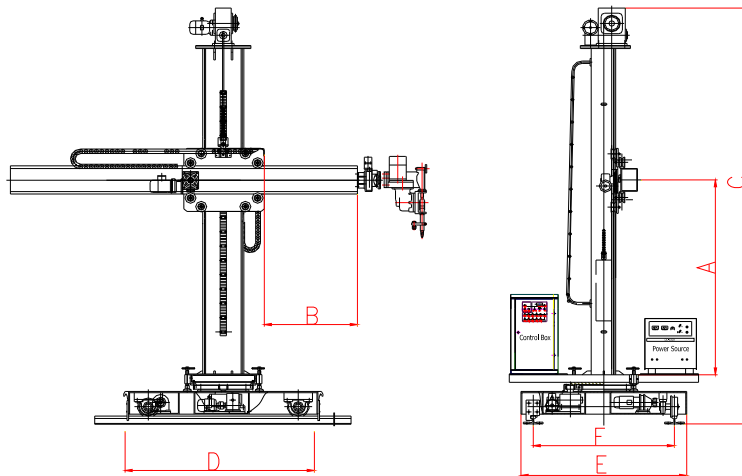

## WELDING MANIPULATORS

# IRIZAR

IRIZAR HEAVY INDUSTRIES INC  
 1512 ADAMSON VIEW, EDMONTON  
 ALBERTA T6W 0V4, CANADA  
 PHONE: 1 780 450 6695  
 WEB: WWW.IRIZAR.COM



Welding Manipulator Remote Control Box

Welding Manipulator Main Control Box



**WM MAIN CONTROL &  
REMOTE CONTROL BOX**



**IRIZAR HEAVY INDUSTRIES INC**  
 1512 ADAMSON VIEW, EDMONTON  
 ALBERTA T6W 0V4, CANADA  
 PHONE: 1 780 450 6695  
 WEB: WWW.IRIZAR.COM



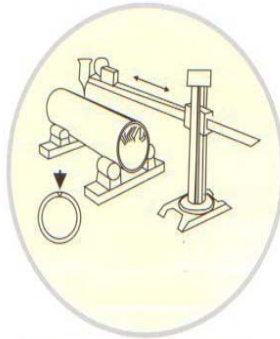

OUTSIDE LONGITUDINAL WELDING

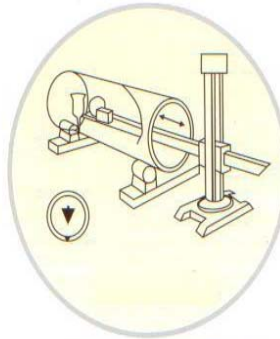

INSIDE LONGITUDINAL WELDING

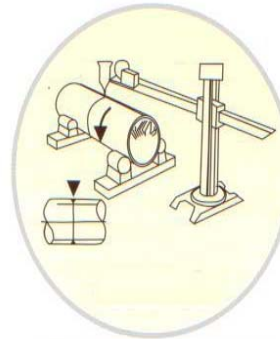

OUTSIDE CIRCUMFERENTIAL WELDING

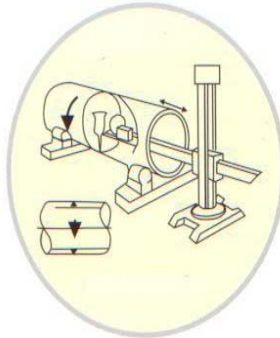

INSIDE CIRCUMFERENTIAL WELDING

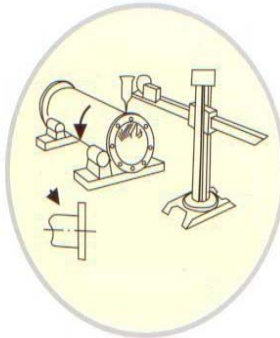

OUTSIDE FLANGE WELDING

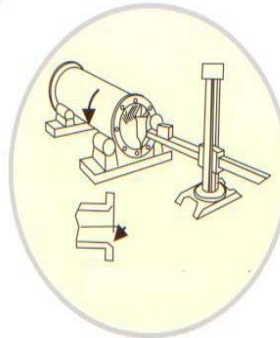

INSIDE FLANGE WELDING

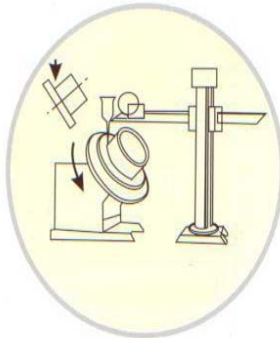

OUTSIDE DOWNWARD FILLET WELDING

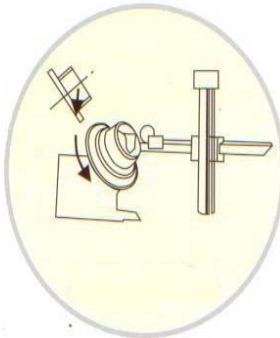

INSIDE DOWNWARD FILLET WELDING

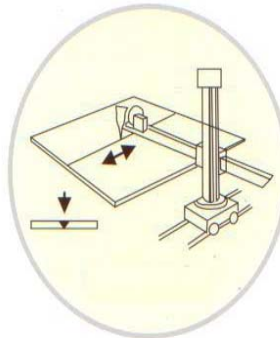

BUTT WELDING OF FLAT PLATE

## APPLICATIONS

**IRIZAR**

**IRIZAR HEAVY INDUSTRIES INC**

1512 ADAMSON VIEW, EDMONTON

ALBERTA T6W 0V4, CANADA

PHONE: 1 780 450 6695

WEB: WWW.JIRIZAR.COM