



IRIZAR HEAVY INDUSTRIES INC

Head Office: 1512 Adamson View, Edmonton, Alberta T6W 0V4, Canada

Factory: 464014 RR 235, County of Wetaskiwin, AB, T0C 1Z0, Canada

Phone: 1 780 450 6695, Fax: 1 780 485 6677

Email: jirizar@jirizar.com Website: www.jirizar.com



SEAM TRACKER MODEL 100

OPERATION MANUAL

OVERLOAD OR MISUSE of a WELDING ROTATOR WILL VOID THE WARRANTY and may cause PROPERTY DAMAGE, BODY INJURIES OR DEATH. Overload a Welding Rotator could damage components without the damage being visible; therefore, an overloaded welding rotator could eventually fail at any given time without previous notice, even when rotator is not fully loaded at moment of the failure. Before operating read carefully and understand the information below. If you have any questions or concerns, please contact us @ 1 877 IRIZAR1 or jirizar@jirizar.com

Revision	August	10	2017
----------	--------	----	------

Note: The information contained in this manual is intended to be accurate. However, the manufacturer retains the rights to make changes in design which may not be include herein



Table of Content

1.0	Technical Data	2
2.0	Components	2
3.0	Main Control Operation	3
4.0	Manual Mode Operation	3
5.0	Automatic Mode Operation	3
	<i>Parameter Number/Values Set Up</i>	<i>3</i>
6.0	Installation with Irizar WM	5
7.0	Warnings	6
8.0	Limited Warranty	6

1.0 Technical Data

DESCRIPTION \ MODEL	Seam Tracker Model 100
Max Loaded Capacity	100 kg
Weight	70 kg
Slide Stroke	X & Y axis. 200 mm each
Slide Speed	170 mm/min
Accuracy	±0.25 mm
Welding Method	Submerge Tandem
Motors Style	DC Precision Motors
Electrical Power	AC220V, 1P, 50/60hz, 2A

2.0 Components

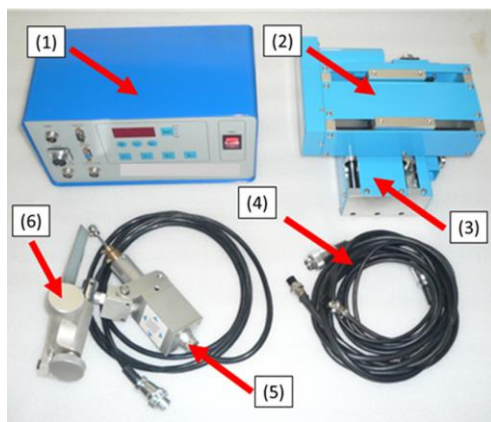

Label	Description	Qty
1	Main Controller	1 unit
2	Left/Right Cross Slide	1 unit
3	Up/Down Cross Slide	1 unit
4	Cables for Cross Slides and Main Power Cable	3 units
5	Finger Probe (one tracking probe included)	1 unit
6	Finger Probe Bracket	1 unit
Optional	Remote Control for Cross Slide	1 unit
	Interface to Lincoln Electric NA-3S controller	1 unit
	Tracking Probes 	7 units



3.0 Main Control Operation

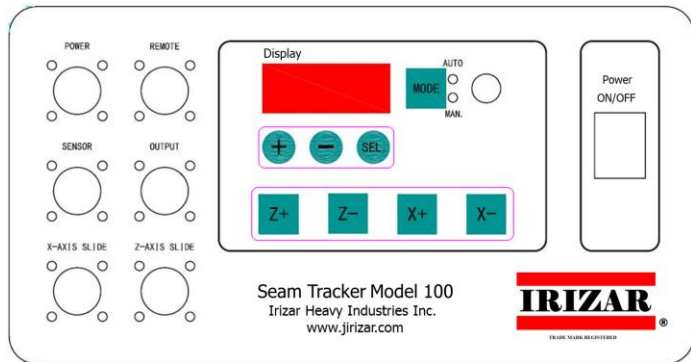

Label	Function
Power On/Off	Powers main controller using toggle button
Mode	Switches between Auto/Man Mode. LED will indicate in mode it is
SEL.	Navigates through Parameters Numbers
(+) / (-)	Navigates through Parameter Values
Z+ / Z-	Manual Control of Up/Down Cross Slide
X+ / X-	Manual Control of Left/Right Cross Slide
Display	Displays Parameter Number/Values
Power	Main Power Outlet
Sensor	Finger Probe Outlet
X-axis Slide	Up/Down Cross Slide Outlet
Z-axis Slide	Left/Right Cross Slide Outlet
Optional	Remote: Remote Control for operating Cross Slide
	Output: Interface to Lincoln Electric NA-3S controller

4.0 Manual Mode Operation

In manual mode, the up/down & left/right cross slide can be operated using the main control (Z+, Z-, X+ and X-) functions. A remote control is also available (sold separately) to control this function.

5.0 Automatic Mode Operation

In automatic mode, the seam tracker automatically tracks and follows a various style of weld seams, weld joints and tack welds based on code numbers and setting range input.

Parameter Number/Values Set Up

There are seven **Code Numbers**.

Each **Code Number** is set up with a **Setting Range** depending on the require tracking.

Code Number and Setting Range are display as below:

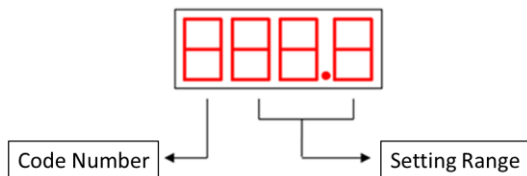

The **Code Number** is changed by Pressing SEL button.

The **Setting Range** is input by using (+) or (-) buttons.

If the SEL, (+) or (-) button is not press after 10 seconds, the controller display will automatically blank out.

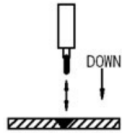
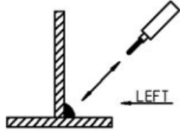
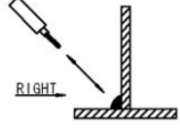
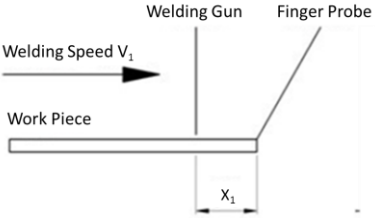
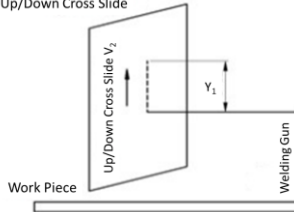

Code Number	Setting Range	Description
0 (Weld Seam Type)	0	Flat seam weld, without tack welds and detects end edge
	1	Girth seam weld and without tack weld
	2	Flat seam, with tack welds and detects end edge
	3	Flat seam / Girth seam welds, without tack welds and does not detects end edge
1 (Weld Joint Type)	0	Butt Joint Style 
	1	Tee (Coming from Left) 
	2	Tee (Coming from Right) 
2 (Position of finger probe)	0	Finger Probe is configured so welding direction is (OUT)
	1	Finger Probe is configured so welding direction is (IN)
3 (Edge detection, horizontal X ₁ delay time before pulling up)	0~21.5 s	 <p> T₁ (seconds) = It is the delay time required to keep the finger probe and welding torche at the same horizontal height for distance X₁, before pulling up. V₁ (mm/seconds) = Welding speed X₁ (mm) = Distance between welding torche and finger probe T₁=(X₁/ V₁)×0.8 </p>
4 (Edge detection, finger probe pull up height Y ₁)	0~21.5 s	 <p> Y₁ (mm) = Rise height (determine by user: 0-80 mm) V₂ (mm/second) = Up/Down cross slide speed (5 mm/seconds) T₂ (second) = Automatic rise time T₂ = Y₁/ V₂ </p>

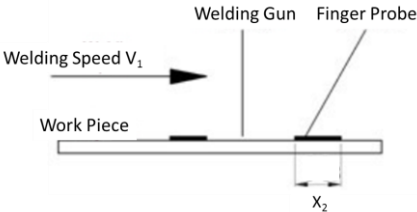

5 (Tack weld detection)	0~20.0 s	 <p>X_2 (mm) = Length of the tack weld V_1 (mm/second) = Welding speed T_3 (second) = Time it takes the finger probe to pass a tack weld of a X_2 length (set T_3 to the longest tack weld length X_2 if they are not uniform)</p> <p>$T_3 = X_2 / V_1$</p>
6 (Finger Probe response time)	0~10.0 s	As the time increase; the longer it takes the finger probe to response to tracking. This value is normally kept as 0.2 seconds, unless there is weld splatter or your steel finish is not clean.

6.0 Installation with Irizar WM

The following components need to be install:

- Left/Right Cross Slide
- Up/Down Cross Slide
- Main Controller
- Probe Bracket: The probe bracket needs to be firmly fixed to its supporting bracket.
- Finger Probe
 - The distance between the welding torch and probe depends on type of welding being done, user needs to determine.
 - The probe needs to be in line with the welding torch.
 - The probe label needs to be facing up.
 - The probe needs to make an angle of 45 degrees respectively to the workpiece.
- Welding Shield: The shield protects the probe from heat being release during the welding process.

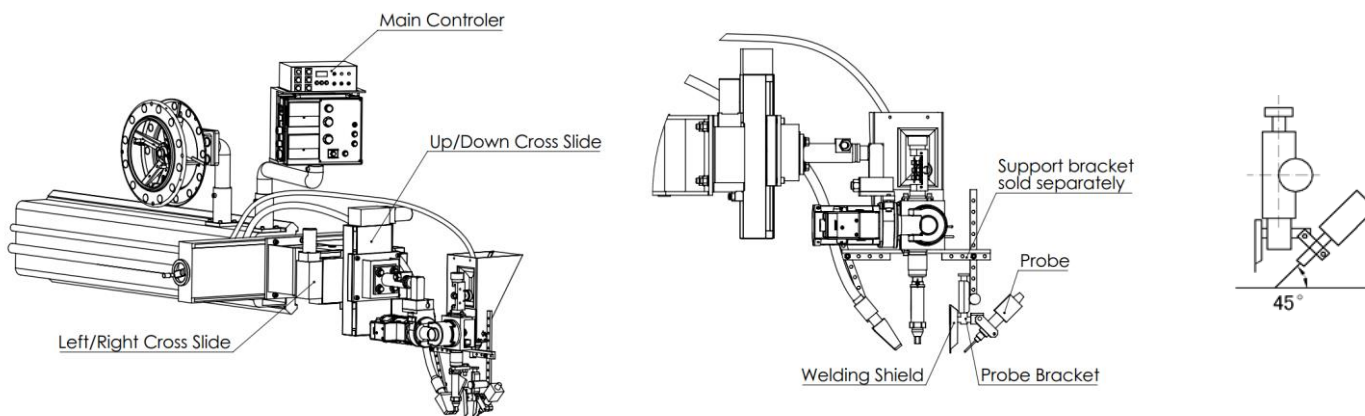

Notes: 1. All brackets for mounting the Irizar Seam Tracker Model 100 are sold separately; compatible only with Lincoln Electric NA-3S welding head, NA-3S welding controller and wire reel. The Irizar Seam Tracker Model 100 is compatible with other brands, user needs to build installation mounting brackets. 2. The diagram shows the Irizar Seam Tracker and other accessories that are sold separately.



7.0 Warnings



WARNING

"Before operating read carefully and understand the information contained on this Operation Manual. If you have any questions or concerns, please contact us @ 1 877 IRIZAR1 or jirizar@jirizar.com"

- Avoid liquids contact with main controller it can cause permanent damage.
- Untrained personal should not operate the Seam Tracker.
- Seam Tracker can only be open for repairs by Irizar trained technician. Warranty will be voided if open by buyer.
- Use finger touch when operating the main controller buttons. Do NOT use hard objects to press buttons.
- Buyer must have read and understood manual prior to operating Seam Tracker. Failure will cause equipment to not function as per its design.

8.0 Limited Warranty

IRIZAR HEAVY INDUSTRIES INC warrants all new equipment to be free from defects in material and workmanship for the period of one year or two thousand (2,000) hours of operation, whichever expires first, provided that the equipment is installed and operated according to instructions. Any repairs or modification made by unauthorized third parties without written consent shall void this warranty. IRIZAR HEAVY INDUSTRIES INC's obligation under this warranty is expressly limited to replacing or repairing any defective part or correcting any manufacturing defect without charge during the warranty period, if IRIZAR's factory inspection confirms the existence of such defects. Exercise of IRIZAR's option of replacement or repair will be at IRIZAR's factory and/or warehouse; therefore, no reimbursement for transportation cost of any kind will be allowed. IRIZAR HEAVY INDUSTRIES INC will not be liable for any loss or consequential damage or expense accruing directly or indirectly from the use of equipment covered by this limited warranty.

The obligations of Seller under this limited warranty are subject, however, to the following conditions:

- a. Buyer shall give prompt notice to Seller of the date on which the Equipment is first placed in service.
- b. Buyer shall give Seller immediate written notice (within the warranty period) of any defect in material or workmanship covered by warranty.
- c. Buyer shall install, maintain, and use the Equipment strictly in accordance with instructions, procedures, or specifications supplied by Seller, and in any event in accordance with industry standards.
- d. Buyer shall ensure that the Equipment is operated only by qualified and properly trained personnel.
- e. Buyer shall not abuse the Equipment by overloading or improper operation, and shall not modify the Equipment or use repair parts other than furnished by Seller, except as approved by Seller in writing.
- f. Any defects or non-conformities in the Equipment, which could be identified on initial inspection or testing of the Equipment by Buyer shall not be covered by warranty unless notice is given to Seller within thirty (30) days after receipt by Customer.

SELLER SHALL IN NO EVENT BE LIABLE FOR ANY INCIDENTAL OR CONSEQUENTIAL DAMAGES RESULTING FROM ANY ALLEGED DEFECTS OR FAILURES OF THE EQUIPMENT, INCLUDING BUT NOT LIMITED TO DAMAGES RELATING TO USE OR LOSS OF USE OF THE EQUIPMENT, OR DELAYS IN MANUFACTURE, DELIVERY, OPERATION, OR USE OF THE EQUIPMENT. Unless otherwise specifically agreed to in writing, in no event shall Seller be directly or indirectly liable for any drawings, designs, parts, items, or materials specified or furnished by the buyer or its agents or suppliers for incorporation into the Equipment. In no event shall any damages in the aggregate payable by Seller as a result of any and all breaches of this contract by Seller exceed one hundred percent (100%) of the price for the Equipment.