



WELDING POSITIONER
MODEL PL

IRIZAR

IRIZAR HEAVY INDUSTRIES INC
1512 ADAMSON VIEW, EDMONTON
ALBERTA T6W 0V4, CANADA
PHONE: 1 780 450 6695
WEB: WWW.IRIZAR.COM



**WELDING POSITIONER
MODEL PL TONS**

IRIZAR

IRIZAR HEAVY INDUSTRIES INC
1512 ADAMSON VIEW, EDMONTON
ALBERTA T6W 0V4, CANADA
PHONE: 1 780 450 6695
WEB: WWW.IRIZAR.COM

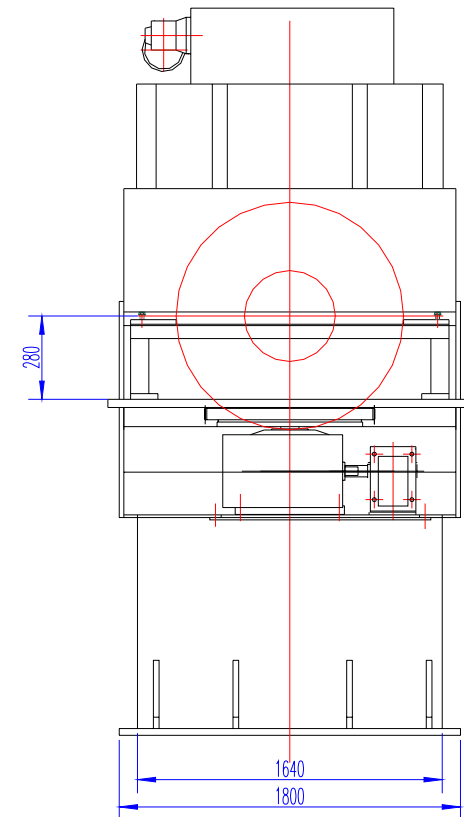
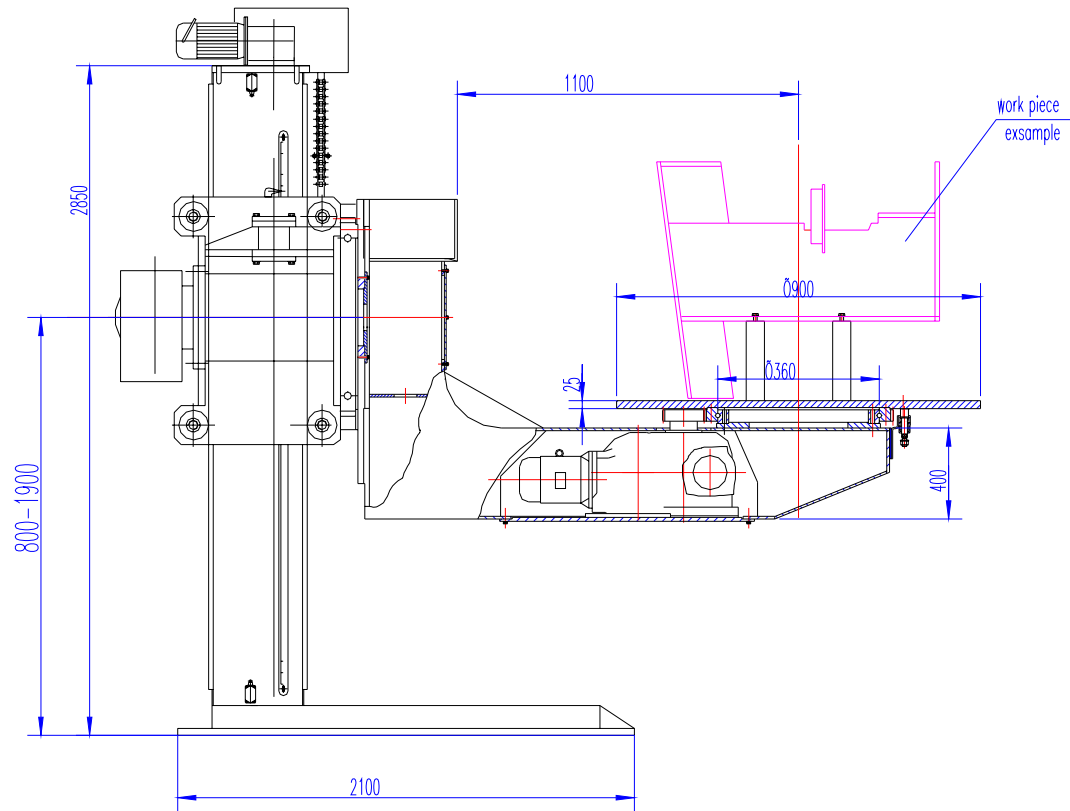

SPECS:

1. Load and rotation capacity: Max 2.5 MT Max
2. Max eccentricity: 200 mm
3. Max GC: 300 mm
4. Rotation center: 800 mm (Min) to 1,900 mm (Max)
5. Rotation speed: 0.015 to 0.15 RPM
6. Tilt speed: 0.10 RMP
7. Elevation speed: 0.45 m/min
8. Table Diameter: 900 mm
9. Max rotation diameter @ 90 degrees: 4,000 mm
10. Rotation motor power: 4 kW

WELDING POSITIONER

MODEL PL 2.5 TONS

IRIZAR

IRIZAR HEAVY INDUSTRIES INC
 1512 ADAMSON VIEW, EDMONTON
 ALBERTA T6W 0V4, CANADA
 PHONE: 1 780 450 6695
 WEB: WWW.JIRIZAR.COM

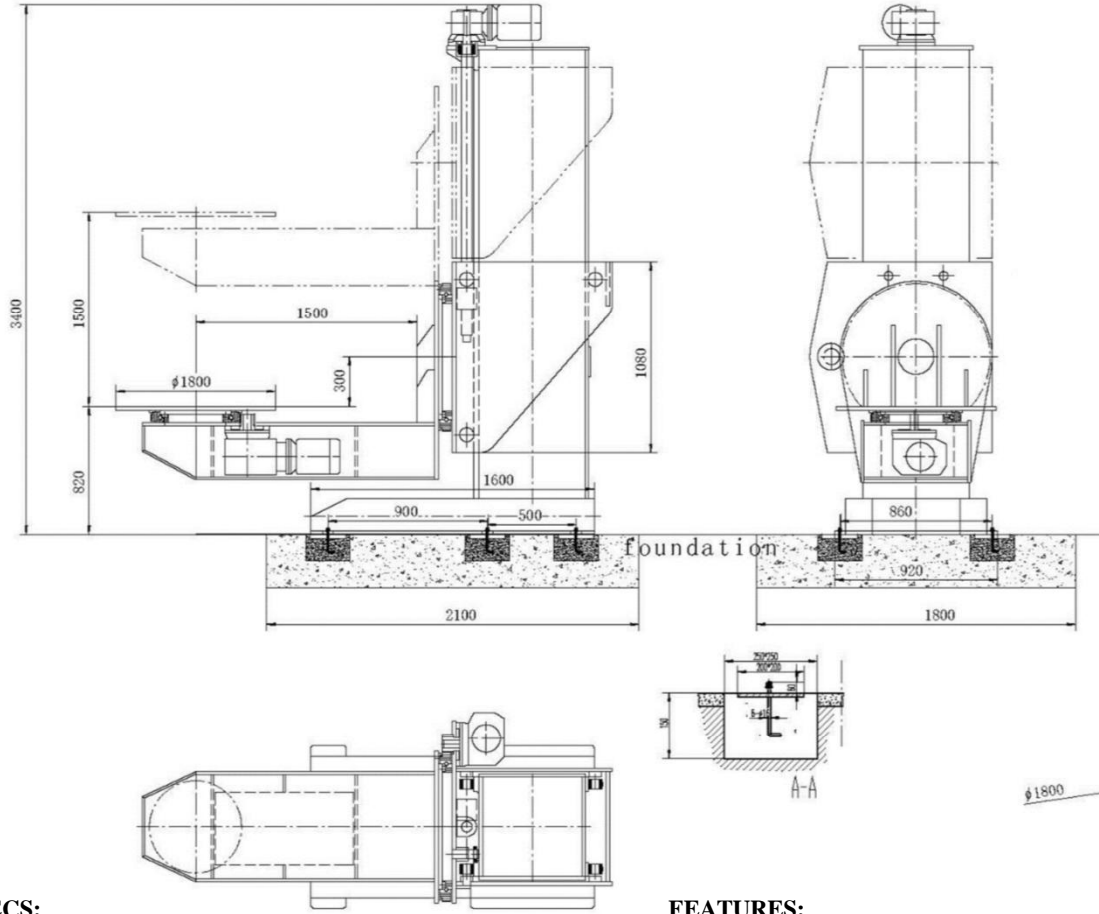

WELDING POSITIONER
MODEL PL 10 MT



IRIZAR HEAVY INDUSTRIES INC
1512 ADAMSON VIEW, EDMONTON
ALBERTA T6W 0V4, CANADA
PHONE: 1 780 450 6695
WEB: WWW.IRIZAR.COM

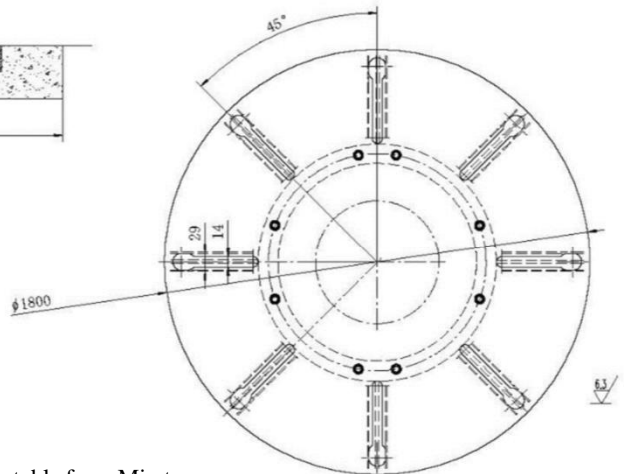

SPECS:

1. Load and rotation capacity: 10 MT Max
2. Max eccentricity: 200 mm
3. Max GC: 300 mm
4. Height adjustment (Min-Max): 820 to 2,320 mm
5. Rotation speed: 0.02 to 0.2 RPM
6. Tilt speed: 0.10 RMP
7. Elevation speed: 0.45 m/min
8. Table Diameter: 1,800 mm
9. Rotation motor power: 3.00 kW @ 2 No
10. Tilt motor power: 5.50 kW @ 2 Nos
11. Elevation motor power: 1.50 kW

FEATURES:

1. Rotation center height: 1) Adjustable from Min to Max; 2) Elevation lifting speed up/down constant
2. **Remote Control Box** with 12 m cable length
 - a. Variable speed on **table rotation**
Forward/Stop/Reverse. Digital display in RPM.
 - b. Tilt speed: Constant
 - c. Height adjustable up/down.
3. Protection class IP54 against dust and heavy rain on electric control box and motors
4. "T" shaped channels on table surface
5. **TECO VFD** (Variable Frequency Driver)
6. Shot blasted frame at SA 2 ½ before being painted